

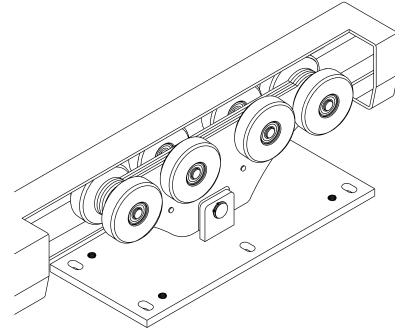

- I** Carrello "Magnum 2" per cancelli autoportanti
- UK** "Magnum 2" carriage for cantilever gates
- D** "Magnum 2" Rollenapparat für freitragende Schiebetore
- F** Chariot "Magnum 2" pour portails autoportants
- E** Carro "Magnum 2" para puertas autoportantes
- RUS** Тележка «Магнум2» для раздвижных ворот

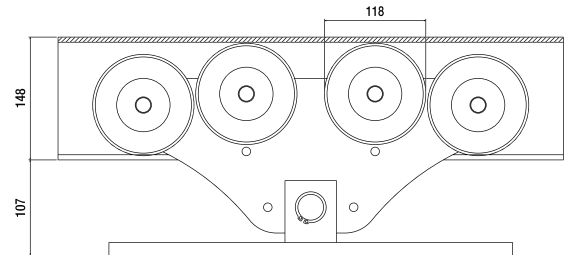

Articolo - Article	L1	Peso max cancello Gate max weight	Abbinabile Combining	
Riferimento - Reference	Max ML			N°
CA 4 RMS 2	LT 01 20 82	2200	GIPI 4 RM 2 / M 2 C	1 45,2

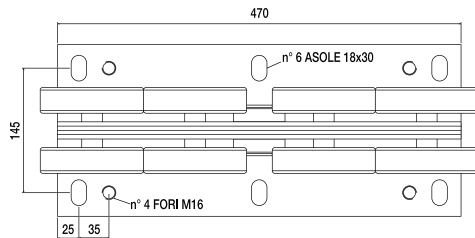
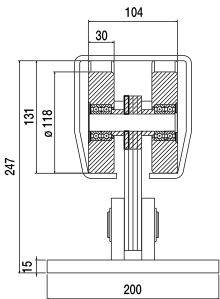

Peso max cancello Gate max weight	L1 (mt)	L2 (mt)	L4 (mt)	L5 (mt)	LT (mt)	H (mt)	E (mt)	A (mt)	B (mt)	C (mt)	Portata max carrello Carriage strength	Fondazione Armatura
2200	9,0	2,7	4,04	0,2	13,0	1,7	0,47	4,2	0,6	0,5	4400	6 Ø 12 4 Ø 12
2200	10,0	3,0	4,34	0,2	14,3	1,7	0,47	4,2	0,6	0,5	4400	6 Ø 12 4 Ø 12
2200	11,0	3,3	4,64	0,2	15,6	1,7	0,47	4,8	0,8	0,6	4400	7 Ø 12 4 Ø 12
2200	12,0	3,6	4,94	0,2	16,9	1,7	0,47	4,8	0,8	0,6	4400	7 Ø 12 4 Ø 12
2200	13,0	3,9	5,24	0,2	18,2	1,7	0,47	5,4	0,8	0,6	4400	9 Ø 12 4 Ø 12
2200	14,0	4,2	5,54	0,2	19,5	1,7	0,47	5,6	1	0,8	4400	9 Ø 12 4 Ø 12
2200	15,0	4,5	5,84	0,2	20,8	1,7	0,47	6	1	0,8	4400	10 Ø 12 4 Ø 12
2200	16,0	4,8	6,14	0,2	22,1	1,7	0,47	6,2	1	0,8	4400	10 Ø 12 4 Ø 12
2200	17,0	5,1	6,44	0,2	23,4	1,7	0,47	6,5	1	0,8	4400	10 Ø 12 4 Ø 12
2200	18,0	5,4	6,74	0,2	24,7	1,7	0,47	7	1	0,8	4400	10 Ø 12 4 Ø 12

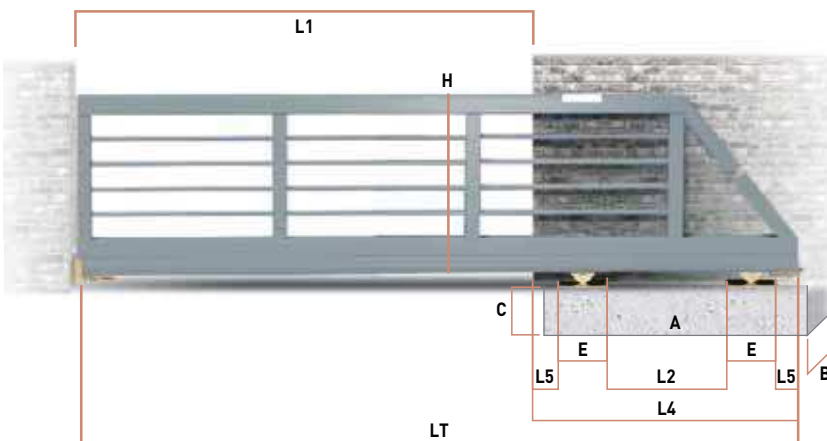
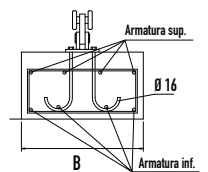

$LT = L1 + L4$ $L2 = 30\% \text{ di } L1$ $L4 = L2 + (E + L5) \times 2$

Accessori Abbinabili / Combining accessories

CA 4 RMS 2 	x2	41 G 	x2	
50 G 	85 G 	x2	GIPI 4 RM 2 / M 2 C 	*
2RGZ / 4RG P 	x2	6 loeck 	x1	

* Lunghezza guida variabile
Variable track length