

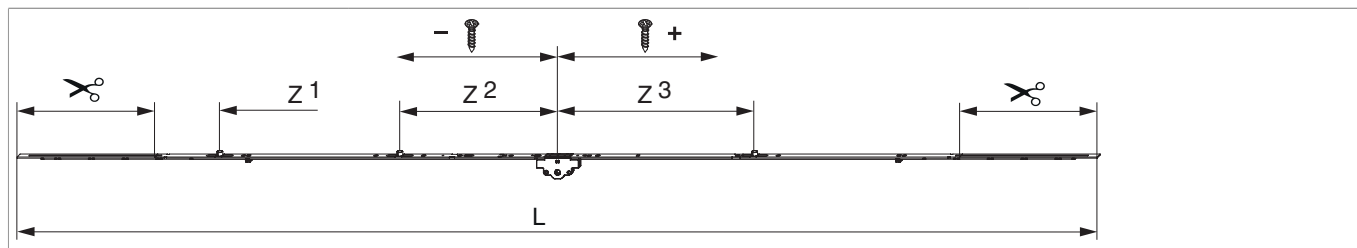

214906 - Cremonese A-B Multi Matic 2250 E30 variabile con 3 nottolini HBB 1.751-2.250 argento

Disegni tecnici



		L					Nº
argento	2250	2.040	30	1.751 - 2.250	260	10	214906

Tabella posizionamento viti

Nº		1	2	3	4	5	6	7	8	
214906	8	-595	-345	-255	-186,5	74	338	415	653	

Tabella punti di chiusura

Nº		Z1	Z2	Z3	
214906	3	-640	-300	370	

Dime

			Nº
Dima forature per serratura bloccabile E 25-50mm	larghezza profilo fino a 110 mm	1	214634



214906 - Cremonese A-B Multi Matic 2250 E30 variabile con 3 nottolini HBB 1.751-2.250 argento

Quote della scatola cremonese

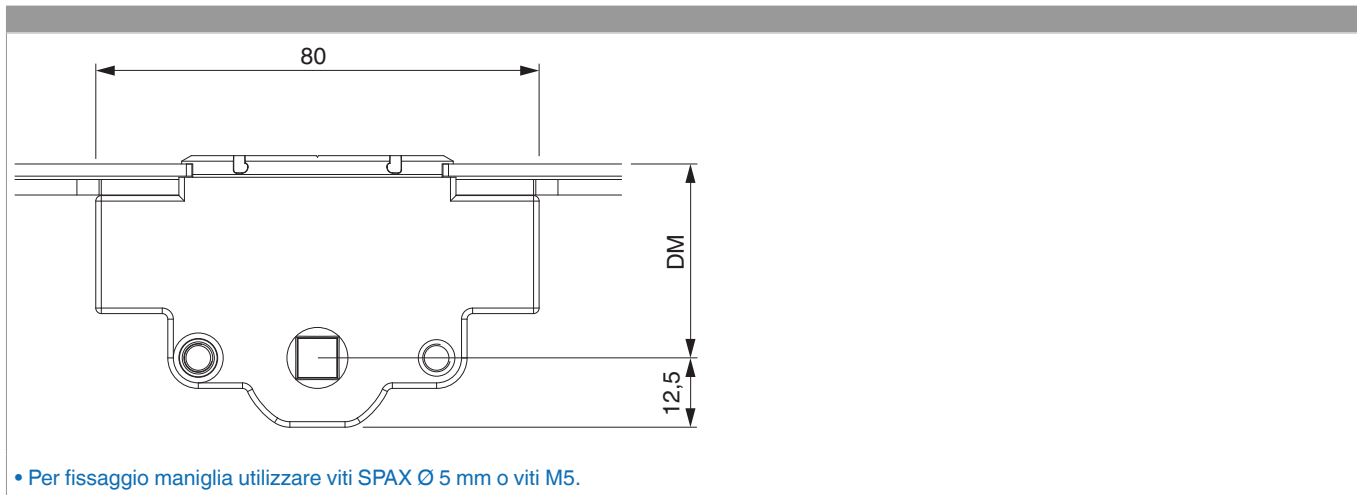

Schema di foratura

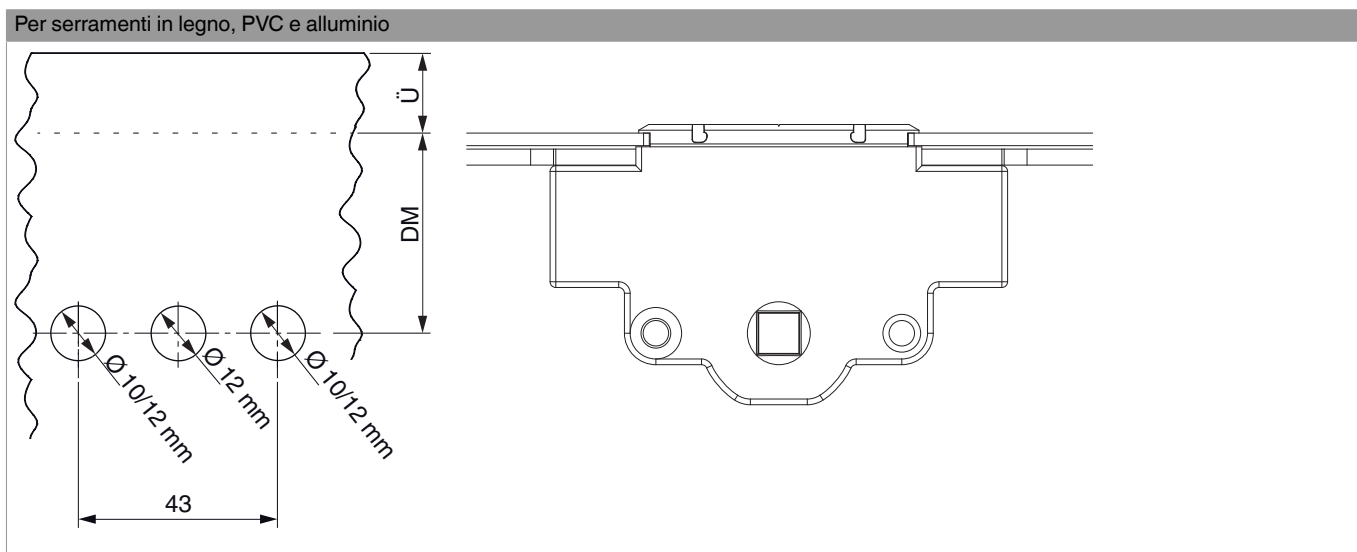



214906 - Cremonese A-B Multi Matic 2250 E30 variabile con 3 nottolini HBB 1.751-2.250 argento

Schema di tranciatura

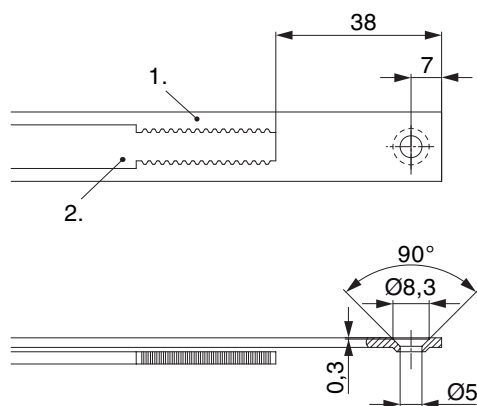

• Consigliamo di trattare il taglio dei componenti TRICOAT-PLUS con la vernice di ritocco TRICOAT-PLUS (cod. 358440).

- 1. Frontale
- 2. Asta mobile

Collegamento scarpetta dentata

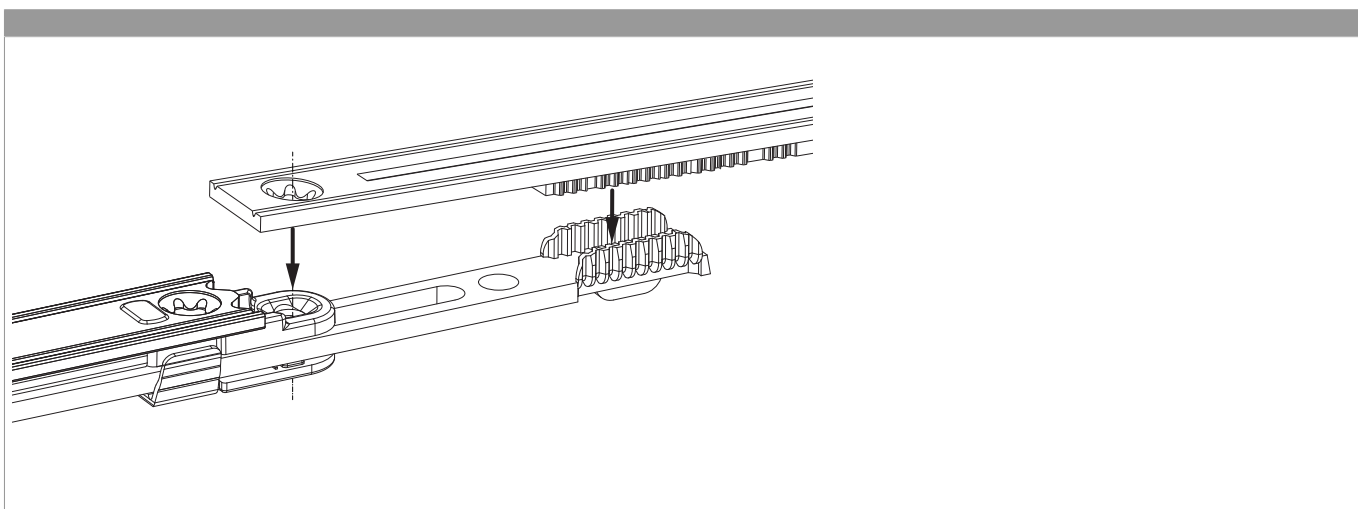



214906 - Cremonese A-B Multi Matic 2250 E30 variabile con 3 nottolini HBB 1.751-2.250 argento

Regolazione pressione

Fungo e nottolino

