

1035

PORTATA MASSIMA  
CARRYING CAPACITY **300 kg**

**PIASTRA GIREVOLE 360° SU SFERE**  
360° BALL BEARING SWIVEL PLATE

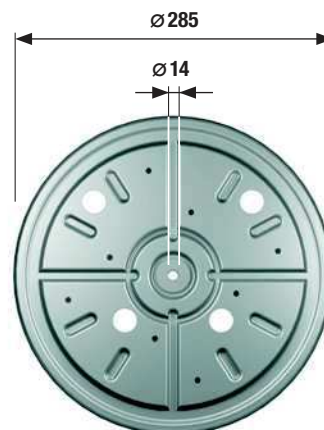

ESEMPI DI APPLICAZIONE / EXAMPLES OF APPLICATION



ISTRUZIONI DI FISSAGGIO / ASSEMBLY INSTRUCTIONS

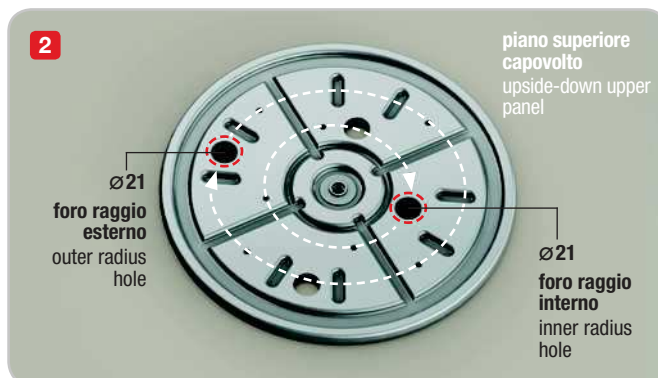

- A** Fissare la piastra rotante nella parte inferiore del piano superiore attraverso i fori da 21 mm.
- B** Ruotare i due dischi della piastra fino a far coincidere i fori da 21 mm e praticare attraverso di essi un foro da 18 mm sul piano superiore.
- C** Appoggiare il piano superiore su quello inferiore con la piastra rotante a contatto del piano inferiore.
- D** Ruotare il piano superiore fino a far coincidere il foro da 18 mm con i fori per le viti sulla parte inferiore della piastra rotante.
- E** Fissare la piastra girevole al piano inferiore con un cacciavite attraverso il foro sul piano superiore.

- A** Fix the rotating plate underside the upper panel through the 21 mm holes.
- B** Rotate the 2 disks of the plate to match the 21mm holes. Drill a 18 mm hole in the upper panel through the 21 mm holes.
- C** Place the upper panel on the lower panel with the rotating plate in contact with the lower panel.
- D** Rotate the upper panel to make the 18 mm hole correspond with the screw holes in the lower disk of the rotating plate.
- E** Fix the rotating plate to the lower panel using a screwdriver through the hole in the upper panel.